

Gebrauchsanleitung  
Installation and Operating Instructions  
Notice de montage et d'installation



RESIDENZA



2023/08/B



.hess



Wichtige Hinweise  
Important Information  
Consignes importantes



**(D)** Montage- und Wartungsarbeiten sind nur mit Originalteilen durchzuführen. Für die Installation und den Betrieb sind die nationalen und internationalen Vorschriften zu beachten. Werden nachträglich Änderungen an Leuchten vorgenommen, so gilt derjenige als Hersteller, der diese Änderungen vornimmt. Hess Licht + Form übernimmt keine Haftung für Schäden, die durch unsachgemäßen Einsatz entstehen. Montage nur durch Fachpersonal.

**(GB)** Only use original parts for maintenance and installation of this luminaire. National and international regulations and laws apply to the installation and operation of this lighting fixture. If modifications are made to the luminaire, the party who made the modifications shall be considered the legal manufacturer thereafter. Hess Licht + Form does not accept liability for any damages that occur due to improper or unskilled actions. Only qualified persons are permitted to install and assemble products obtained from Hess Licht + Form.

**(F)** Tous travaux de montage et d'entretien ne doivent être effectués qu'avec des pièces d'origine. Observez les consignes de sécurité électriques nationales et internationales lors de l'installation et lors du fonctionnement. En cas de modifications ultérieurement apportées aux luminaires, la personne responsable de ces modifications est considérée comme le fabricant. Hess Licht + Form n'assume aucune responsabilité pour les dommages résultant d'une utilisation non conforme. Le montage ne doit être effectué que par des spécialistes.



**(D)** Es dürfen nur die vom Leuchtenhersteller vorgeschriebenen Ersatzteile eingesetzt werden. Die Vorschriften der Lampenhersteller sind zu beachten.

**(GB)** Only replacement parts specified by the lighting fixture manufacturer may be used. In addition, the lamp manufacturer's instructions must be followed.

**(F)** Seules les pièces de rechange prévues par le fabricant des luminaires doivent être utilisées. Observez les consignes du fabricant de lampes.



**(D)** LED-Modul: Risikogruppe 2, nicht in den Strahl blicken!  
Die Leuchte ist so zu positionieren, dass längeres in die Leuchte schauen in einem geringeren Abstand als 0,4m nicht zu erwarten ist.

**(GB)** LED module risk group 2, do not look into the beam!  
Position the luminaire to avoid extended viewing into the luminaire at a distance of less than 0,4m.

**(F)** Module LED, groupe des risques 2, ne pas regarder le rayon.  
Positionnez le luminaire afin d'éviter d'y regarder longtemps à une distance inférieure à 0,4m.



**(D)** Die Lichtquelle dieser Leuchte darf nur vom Hersteller oder einem von ihm beauftragten Servicetechniker oder einer vergleichbar qualifizierten Person ersetzt werden.“

**(GB)** The light source of this lamp may only be replaced by the manufacturer or a service technician commissioned by him or a comparable qualified person.

**(F)** La source lumineuse de cette lampe ne peut être remplacée que par le fabricant ou un technicien de service mandaté par lui ou par une personne qualifiée comparable.

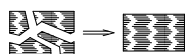

**(D)** Die Leuchte darf nur mit kompletter Schutzabdeckung betrieben werden.

**(GB)** Only operate this luminaire when it is in a closed state, i.e. with closed cover.

**(F)** Ne faire fonctionner le luminaire qu'avec le couvercle de protection fermé.

**(D)** Bei Wartungsarbeiten und beim Lampenwechsel muß das Element spannungsfrei sein.  
Es muß Schutzkleidung getragen werden.

**(GB)** When performing maintenance and changing the lamp, always make sure that the power is off in the luminaire (entire column). Protective clothing must be worn.

**(F)** Lors de tous travaux d'entretien et lors du remplacement d'une source lumineuse, il faut absolument mettre le module hors circuit.  
Il faut absolument porter un vêtement protecteur.

**(D)** FELV-Stromkreise sind gegen die Niederspannungsversorgung (LV) mindestens durch Basisisolierung (basierend auf einer Arbeitsspannung gleich der Spannung der Niederspannungsversorgung) isoliert.

**(GB)** FELV circuits are protected against the low voltage supply (LV) at least by Basic insulation (based on a working voltage equal to the voltage of the low voltage supply)

**(F)** Les circuits FELV sont protégés contre l'alimentation basse tension (BT) au moins par isolation de base (basée sur une tension de service égale à la tension de l'alimentation basse tension)



**(D)** ACHTUNG! Zerstörungsgefahr!  
Chemikalien und Materialien mit korrodierenden Wirkungen dürfen nicht auf die Leuchte einwirken.  
Schrauben leicht fetten.

**(GB)** CAUTION! Damage may occur! Do not allow chemicals or other corrosive materials to come in contact with the luminaire.  
Apply a little grease to the screws.

**(F)** ATTENTION ! Risque de destruction ! Ni produits chimiques ni matières à effet corrosif ne doivent pouvoir agir sur le luminaire.  
Graisser légèrement les vis.



**(D)** Zur Vermeidung von Gefährdungen darf eine beschädigte äußere flexible Leitung dieser Leuchte ausschließlich vom Hersteller, seinem Servicevertreter oder einer vergleichbaren Fachkraft ausgetauscht werden.

**(GB)** To avoid hazards, a damaged outer flexible cable of this lamp may only be replaced by the manufacturer, his service representative or a comparable specialist.

**(F)** Pour éviter tout danger, un câble flexible extérieur endommagé de cette lampe ne peut être remplacé que par le fabricant, son représentant de service ou un spécialiste comparable.

**(D)** Vorbereitende Arbeiten zum Aufstellen des Mastes entnehmen Sie bitte der separaten Empfehlung.

**(GB)** Please refer to the separate recommendation for preparatory work for erecting the pole.

**(F)** Concernant les travaux préliminaires pour l'installation du mât merci de consulter la recommandation ci-jointe.

**(D)**



**(GB)**



**(F)**



**(D)** PMMA Reinigung  
Leuchtenabdeckungen aus PMMA-Kunststoff dürfen nur mit Wasser und Spülmittel, bei starken Verschmutzungen mit Waschbenzin gereinigt werden. Andere Mittel sind nicht erlaubt, insbesondere die Verwendung von alkoholhaltigen Reinigern (Spiritus, Glasreiniger, etc.) oder Kaltreinigern führen zur Beschädigung der Oberfläche.

**(GB)** PMMA cleaning instructions  
Only use a mild detergent and water to clean luminaire covers and enclosures of PMMA plastic. If the PMMA is very heavily soiled, you may use benzene, but with great care and sparingly. Do not use any other agents; in particular, alcohol-containing cleaners (spirits, glass cleaner, etc.) or cold cleaning solvents will damage the surface of the PMMA.

**(F)** Conseil de nettoyage  
Les couvercles de luminaire en matière plastique (de verre acrylique) sont à nettoyer exclusivement avec de l'eau et un produit vaisselle, l'éther de pétrole est autorisé en cas d'encrassements tenaces. Tout autre produit est pros crit, notamment l'emploi de détergents contenant de l'alcool (white-spirit, produits pour vitres, etc.) ou de détergents à froid qui endommageraient la surface.



Lieferumfang  
Included in Luminaire Purchase  
Matériel fourni

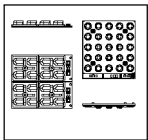
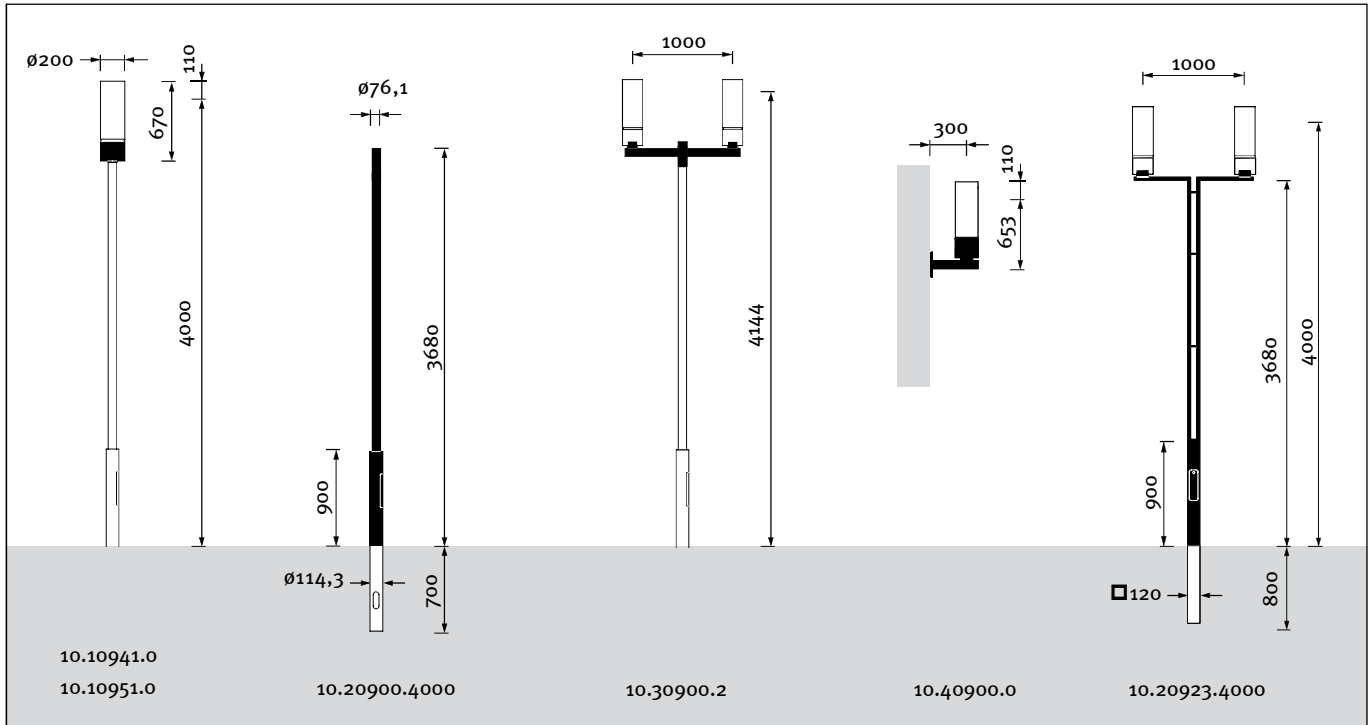

Lichttechnik  
Optical system  
Technique d'éclairage

	LEVO Q	LEVO 3
	30W	23W
RESIDENZA	•	•
RESIDENZA D	•	•

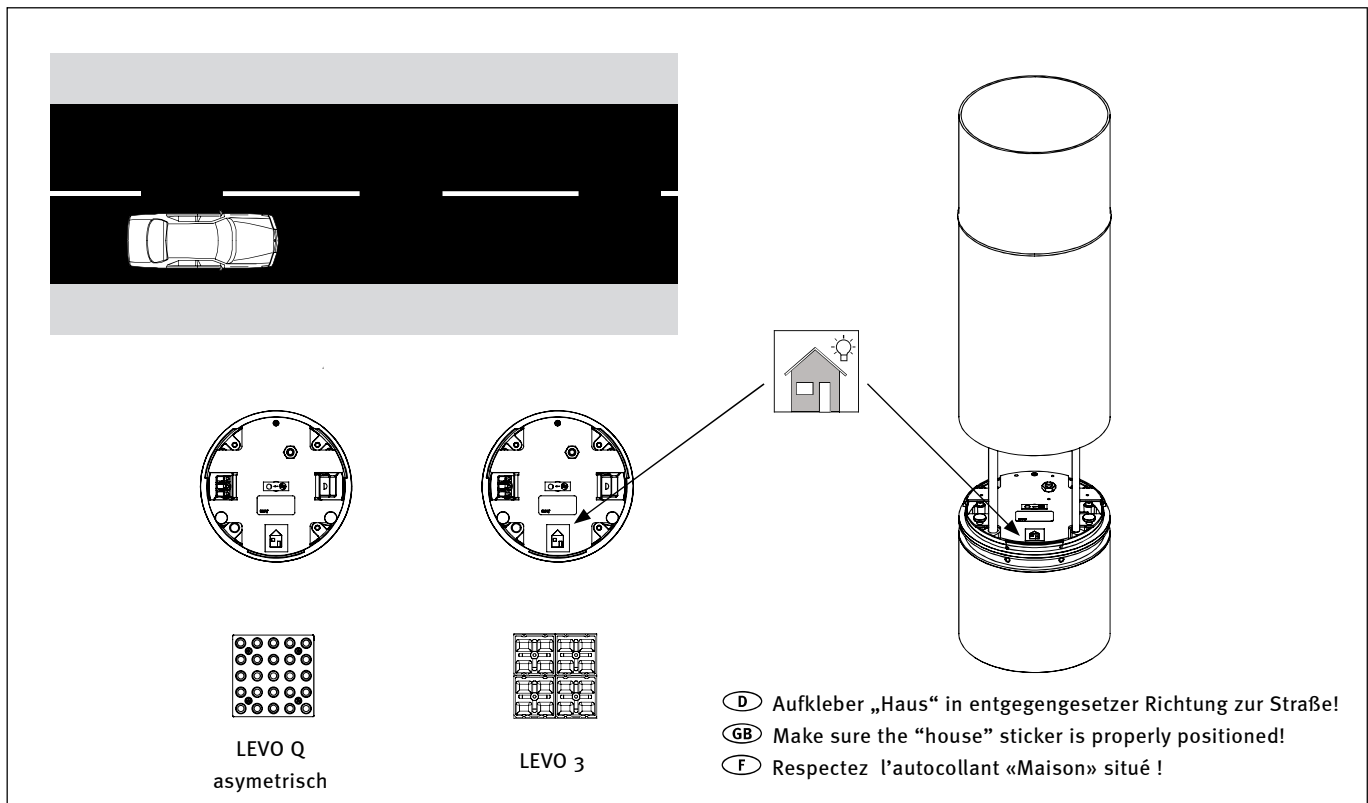



Empfohlene Montagefolge  
Recommended Installation Procedure  
Déroulement de montage recommandé

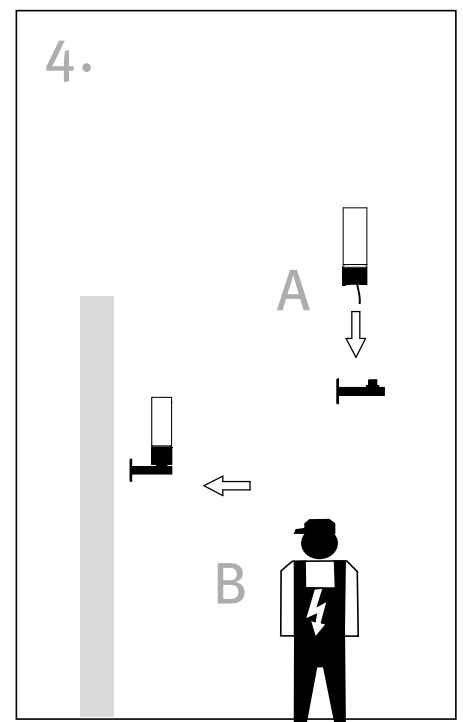
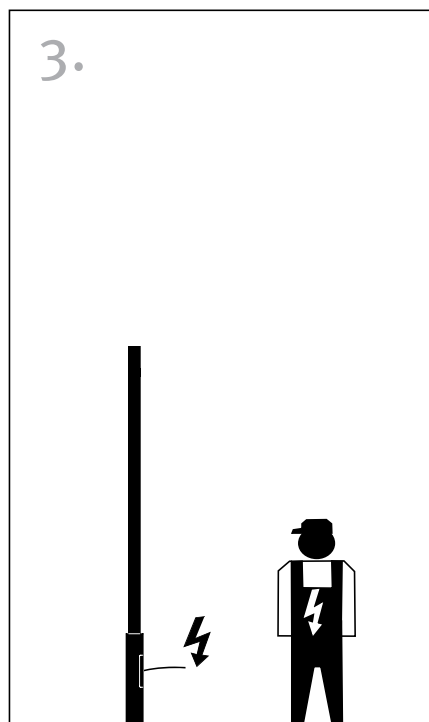
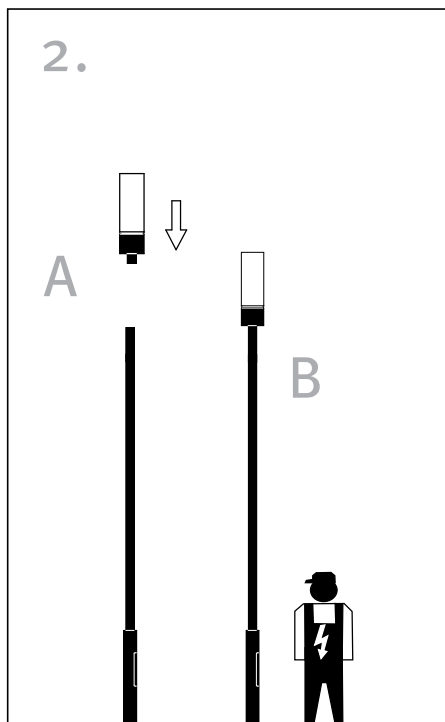
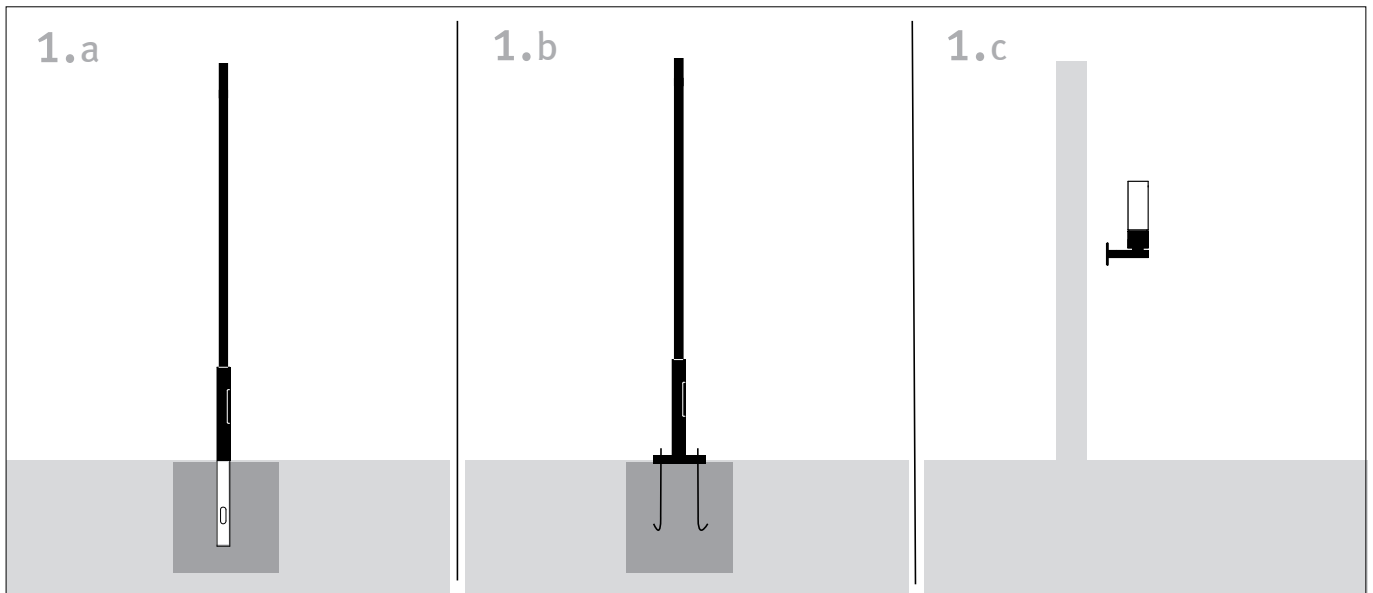

5.

- D** Kabelbelegung
- GB** Wiring diagram
- F** Positionnement brins de câble

6.

- D** Einstellmöglichkeiten "DIM Modul"
- GB** Settings "DIM Modul"
- F** Possibilités de réglage du "Module DIM"

7.

- D** Wartung
- GB** Maintenance
- F** Entretien

8.



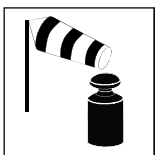
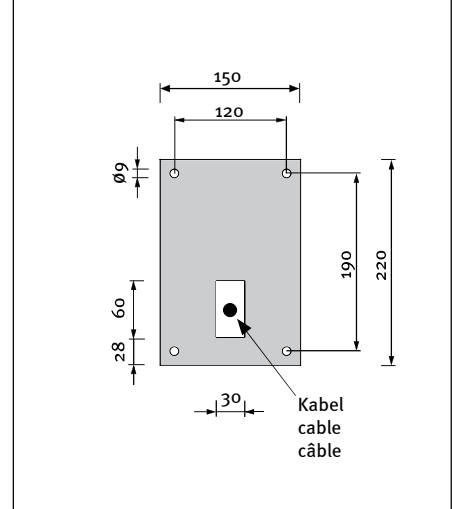
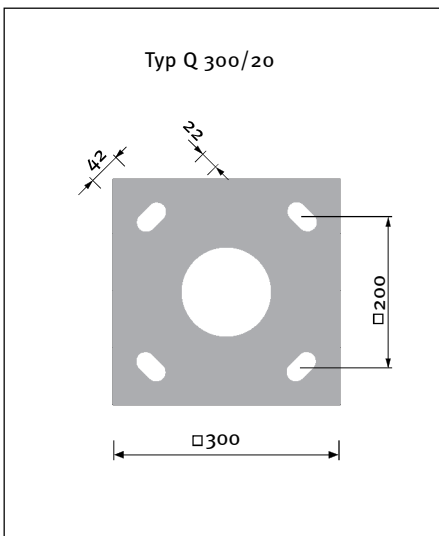
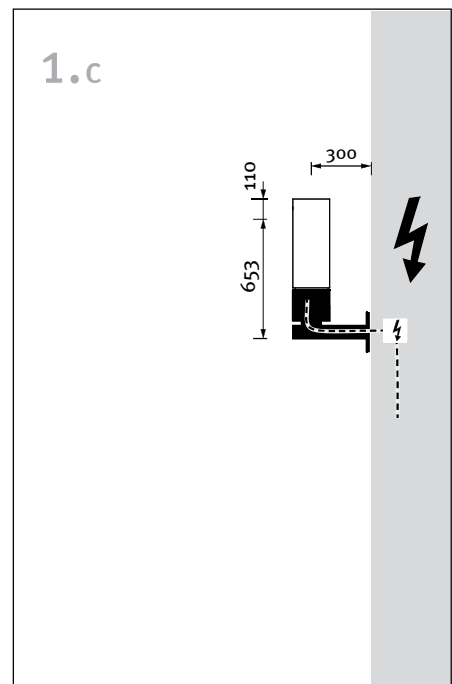
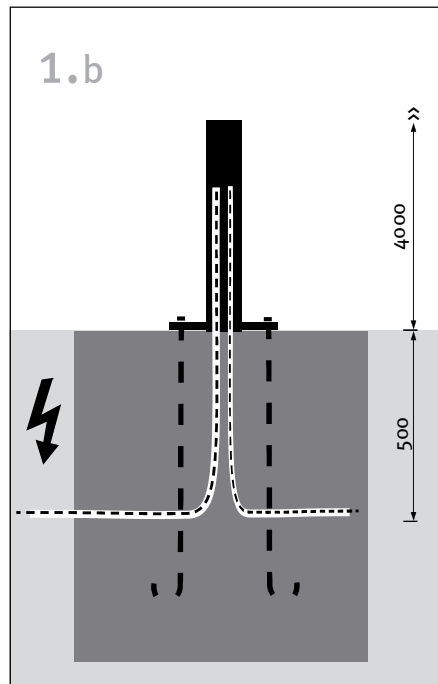
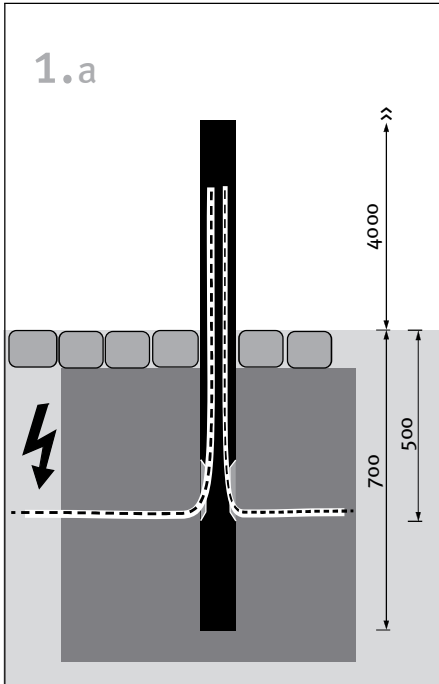

- D** Zubehör
- GB** Accessories
- F** Équipement

# 1.

Mast aufstellen / Wandarm montieren  
 Putting Up the Pole / Mounting the Bracket  
 Ériger le mât / Monter la console



Gewichte / Windangriffsflächen  
 Weight / Wind Catching Surface  
 Poids / Surface de résistance au vent

	Artikel-Nr. mm	 kg	 kg	 kg	 m <sup>2</sup>
RESIDENZA	10.10941.0 / 10.10951	8	–	–	0,005
	10.00900.4000			42	0,32
	10.40900.0		9		0,006
RESIDENZA D	10.00903.4000			78	0,32

# 2.

Montage  
Mounting  
Montage

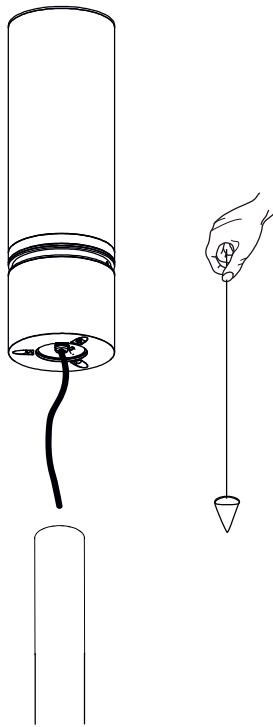

- D** Auf Ausrichtung achten!
- GB** The positioning of the luminaire is critical!
- F** Veiller à la bonne orientation!

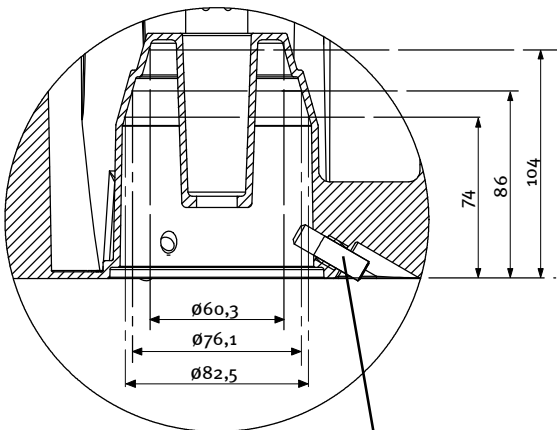
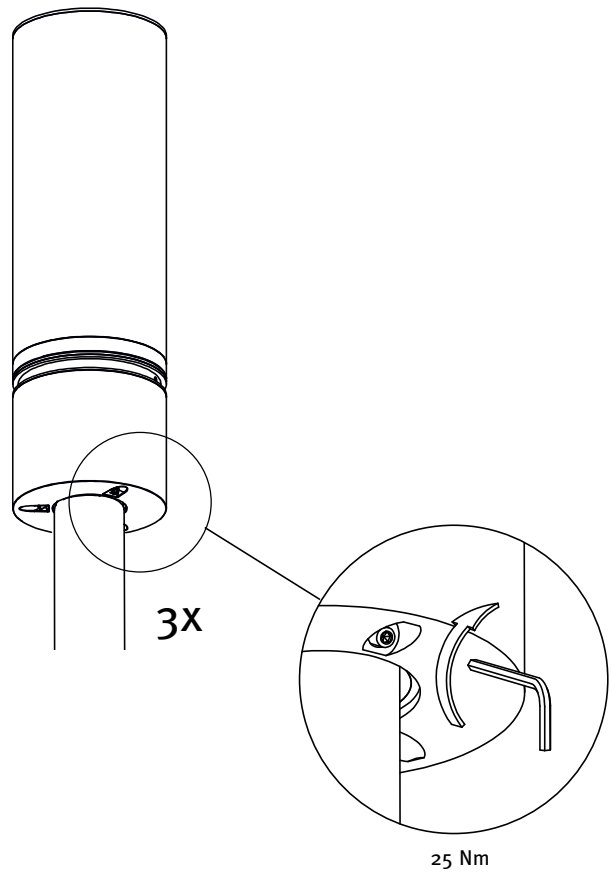

- ø60,3mm = 3x DIN 913 M10x35
- ø76,1mm = 3x DIN 913 M10x25
- ø82,5mm = 3x DIN 913 M10x25

# 3.

Kabelübergangskasten  
Junction Box  
Boîtier de raccordement

## 3.1

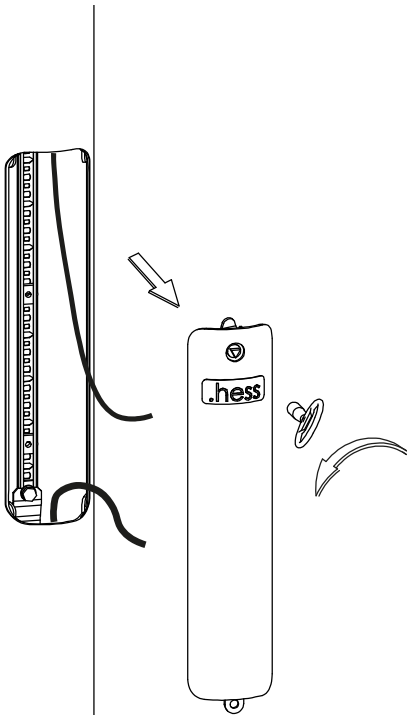

## 3.2

**(D)** ACHTUNG: Die mit X markierte Anschlussbelegung in der Spalte „Variante“ beachten

**(GB)** ATTENTION: Please note the assignment of connections as marked with X in the column "Variante"

**(F)** ATTENTION: Merci de noter l'affectation des raccordements, marquée par „X“ dans la colonne Variante

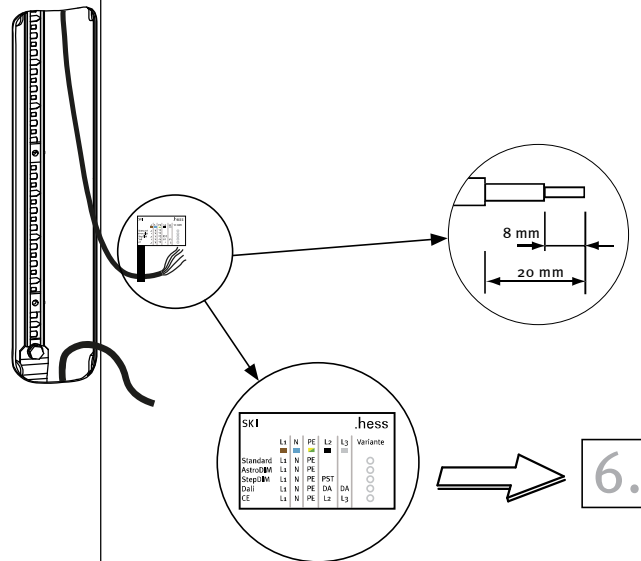

## 3.3

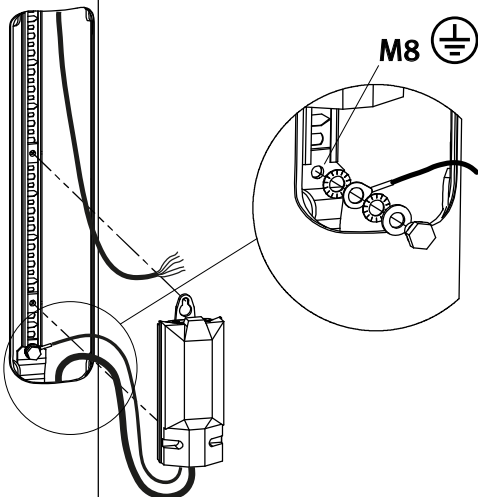

**(D)** Der Kabelübergangskasten ist nicht im Lieferumfang enthalten, er muss VDE, ENEC und für die Montage auf C-Schienen zugelassen sein, sowie der Schutzklasse und Schutzart der Leuchte entsprechen. Die Schraubenanschlussklemmen müssen für das Auflegen der verwendeten Kabel zugelassen sein.  
Empfehlung: TYCO EKM 2051

**(GB)** The junction box does not come with the purchase of the luminaire. It must be VDE- and ENEC-approved. In addition, it must be approved for mounting to C-profile tracks and must be suitable for use with the respective luminaire's Protection Rating and Ingress Protection classifications. The screw terminals must also be suitable for the respective wiring that is used.  
Recommendation: TYCO EKM 2051

**(F)** Le boîtier de raccordement n'est pas inclus dans la livraison. Il doit être homologué VDE/ENEC ainsi que pour son montage sur des rails de transport et il doit correspondre à la classe électrique et à l'indice de protection du luminaire. Les bornes à vis doivent permettre d'appliquer des câbles utilisés.  
Recommandation: TYCO EKM 2051



# 4.

Montage  
Mounting  
Montage

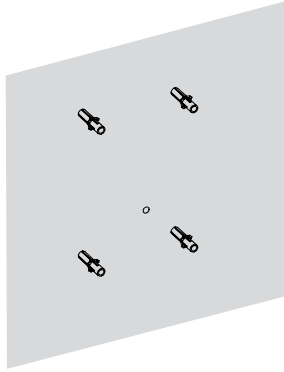

- (D) Nicht im Lieferumfang
- (GB) Not included in luminaire purchase
- (F) Pièces non fournies

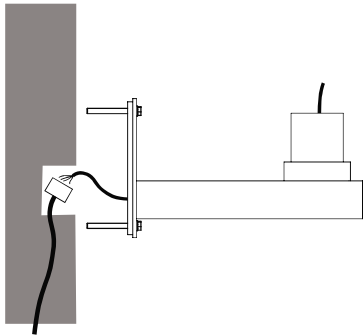
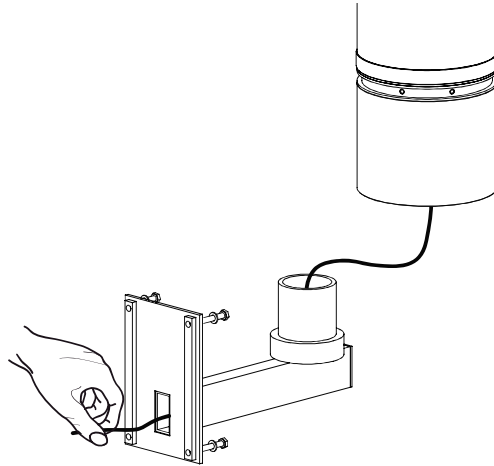

- (D) Aufkleber „Haus“ in entgegengesetzter Richtung zur Straße!
- (GB) Make sure the "house" sticker is properly positioned!
- (F) Respectez l'autocollant «Maison» situé !

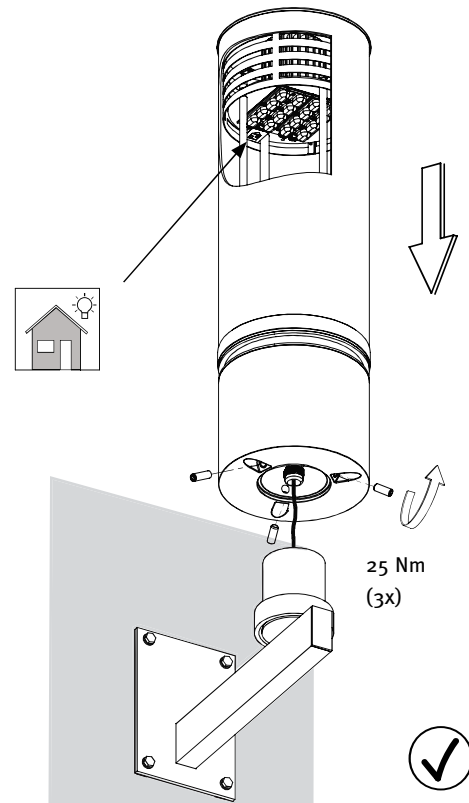
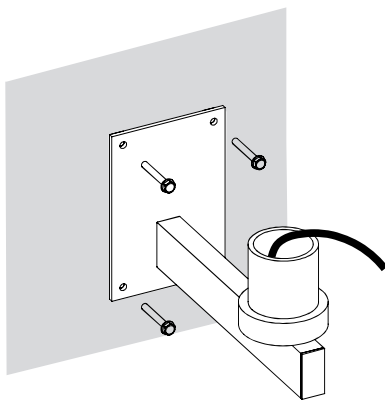

# 5.

Kabelbelegung  
Wiring diagram  
Positionnement brins de câble

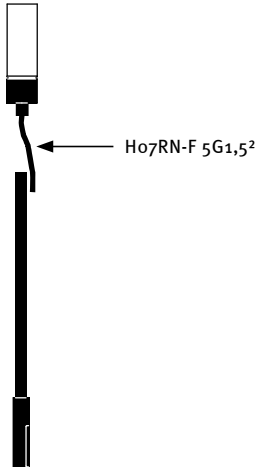

Ho7RN-F 5G1,5<sup>2</sup>

- (D)** Schutzklasse I+II
- (GB)** Protection rating I+II
- (F)** Classe électrique I

Standard / Nachtabsenkung  
default / night economy feature  
défaut / réduction de puissance la nuit

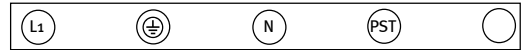

braun brown brun	grün/gelb green/yellow vert/jaune	blau blue bleu	schwarz black noir	grau grey gris
------------------------	---	----------------------	--------------------------	----------------------

Ho7RN-F 5G1,5<sup>2</sup>

- (D)** Schutzklasse I+II
- (GB)** Protection rating I+II
- (F)** Classe électrique I+II

Dali  
Dali  
Dali

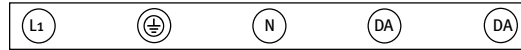

braun brown brun	grün/gelb green/yellow vert/jaune	blau blue bleu	schwarz black noir	grau grey gris
------------------------	---	----------------------	--------------------------	----------------------

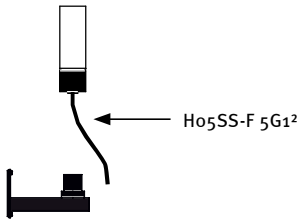

Ho5SS-F 5G1<sup>2</sup>

- (D)** Schutzklasse I+II
- (GB)** Protection rating I+II
- (F)** Classe électrique I

Standard / Nachtabsenkung  
default / night economy feature  
défaut / réduction de puissance la nuit



braun brown brun	grün/gelb green/yellow vert/jaune	blau blue bleu	schwarz black noir	grau grey gris
------------------------	---	----------------------	--------------------------	----------------------

Ho5SS-F 5G1<sup>2</sup>

- (D)** Schutzklasse I+II
- (GB)** Protection rating I+II
- (F)** Classe électrique I+II

Dali  
Dali  
Dali

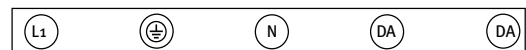

braun brown brun	grün/gelb green/yellow vert/jaune	blau blue bleu	schwarz black noir	grau grey gris
------------------------	---	----------------------	--------------------------	----------------------

○ = nicht belegt / not allocated / non affecté

# 6.

Einstellmöglichkeiten "DIM Modul"  
 Settings "DIM Modul"  
 Possibilités de réglage "Module DIM"

## 6.1 StepDim

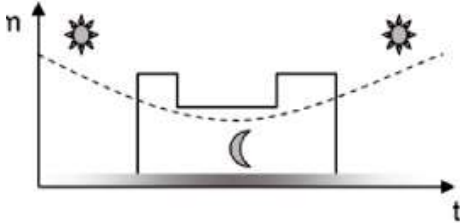

- (D)** Nachtabsenkung über Steuerleitung  
 Absenkung auf 30% / 50% / 70%  
 (weitere Stufen auf Anfrage)  
 Programmierung via Software  
 Serienmäßig integriert
- (GB)** Dims via a control lead  
 Dims to 30% / 50% / 70%  
 (For other dim levels, consult factory)  
 Programmes via software  
 Features above are standard
- (F)** Réduction de puissance nocturne avec ligne de commande  
 Réduction sur palier de 30% / 50% / 70%  
 (autres paliers sur demande)  
 Programmation via logiciel (software)  
 Intégrée en série

## 6.2 AstroDim

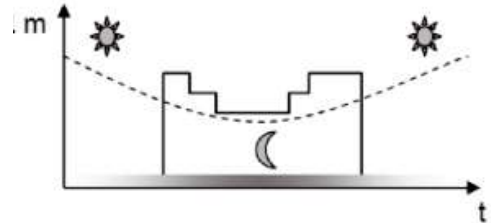

- (D)** Nachtabsenkung ohne Steuerleitung  
 Dimmung auf 2 Absenkstufen möglich  
 Programmierung via Software  
 Theoretische Mitternacht wird selbständig ermittelt  
 Serienmäßig integriert
- (GB)** Dims without using a control lead  
 2 stages are possible  
 Programmes via software  
 Automatically determines when midnight is (approximate)  
 Features above are standard
- (F)** Réduction de puissance nocturne sans ligne de commande  
 Gradation d'éclairage possible sur 2 paliers de réduction  
 Programmation via logiciel (software)  
 L'heure de minuit théorique est déterminée de façon indépendante  
 Intégrée en série

## 6.3 Dali

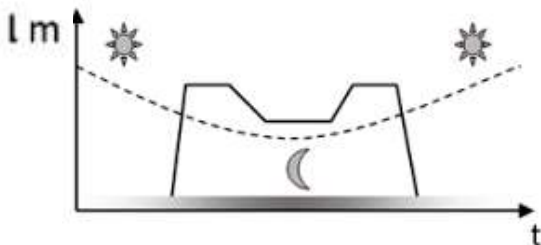

- (D)** Ansteuerbar über diverse Telemanagementsysteme (Zigbee, Powerline, ...)  
 Dimmung von 10% bis 100%  
 einstellbar (Kunde)  
 Serienmäßig integriert
- (GB)** Operable and controllable in various communication networks  
 (Zigbee, Power line, etc.)  
 Dim levels from 10% to 100% possible (customer-set)  
 Features above are standard
- (F)** Pilotable au moyen de divers systèmes de management à distance (Zigbee, Powerline, ...)  
 Gradation d'éclairage réglable de 10% à 100% (client)  
 Intégrée en série.

# 7.

Wartung  
Maintenance  
Entretien

## 7.1

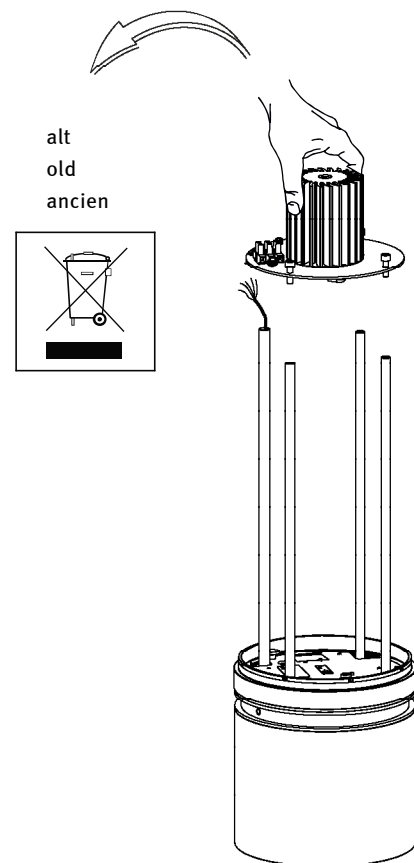
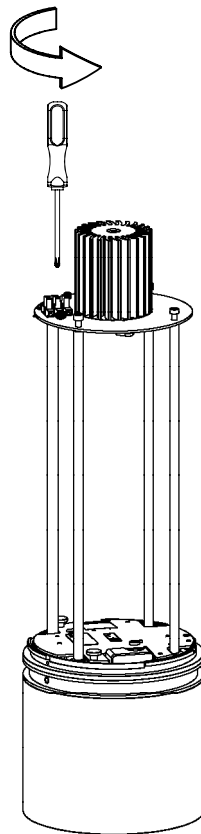
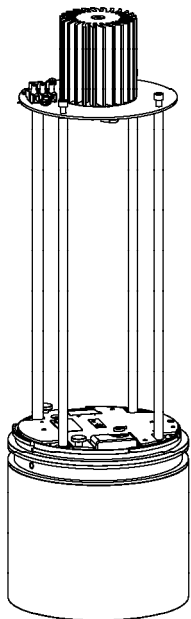
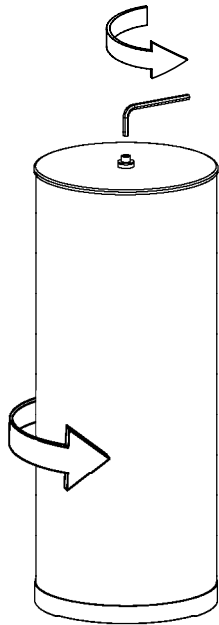

Ⓓ Die Leuchte ist weitestgehend wartungsfrei. Es ist jedoch auch vorgesehen, dass das LED-Modul getauscht werden kann.

ⒼⒷ The luminaire is almost maintenance free. However, it is planned that the LED module can be exchanged.

Ⓕ Le luminaire ne nécessite quasiment aucune maintenance. Toutefois, la possibilité d'un échange du module LED a été prévue.

7.2

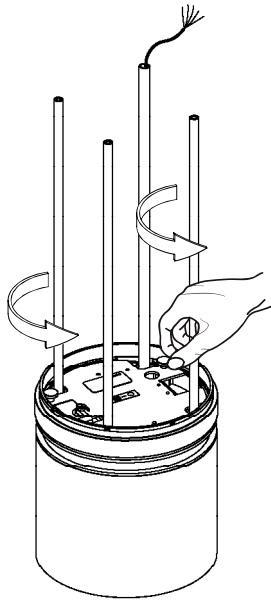

alt  
old  
ancien

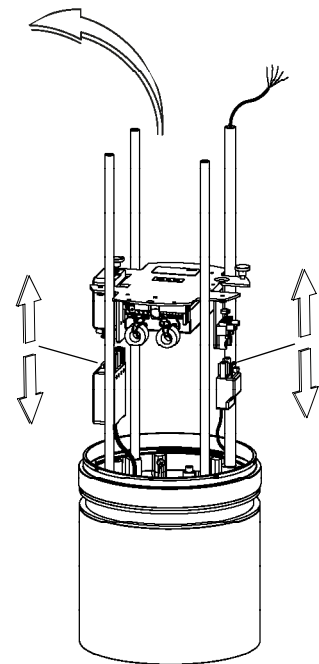
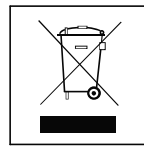

neu  
new  
nouveau

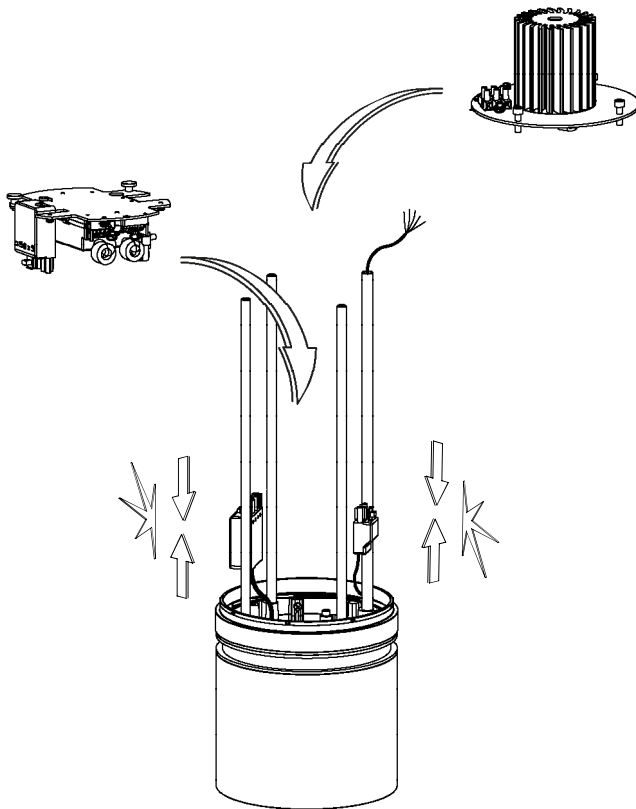

# 7.

Wartung  
Maintenance  
Entretien

## 7.3



Wichtige Hinweise  
Important Information  
Consignes importantes

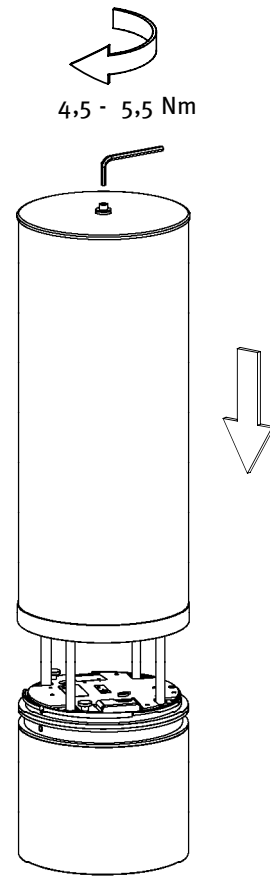
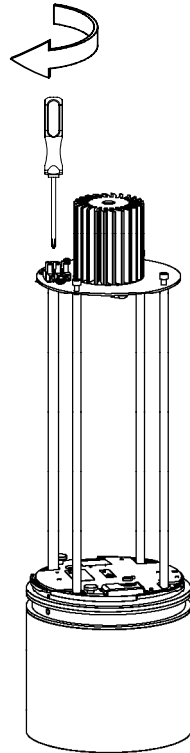

## 8.1

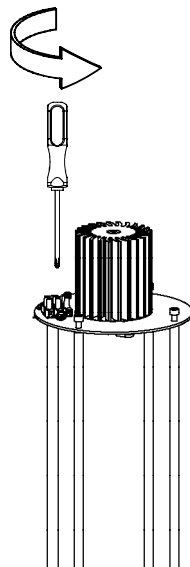
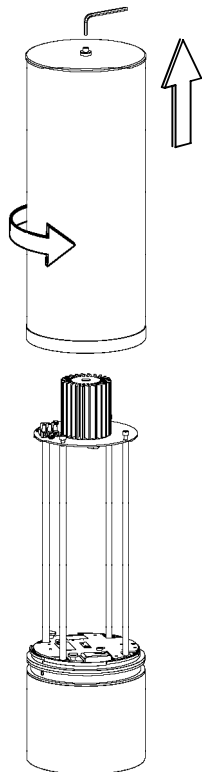

## 8.



Zubehör / Diffusor  
Equipment / Diffuser  
Équipement / Diffuseur

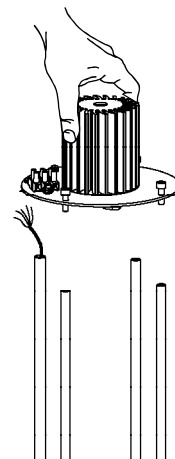

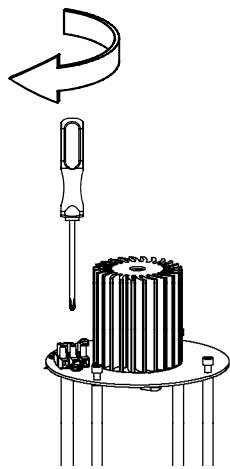
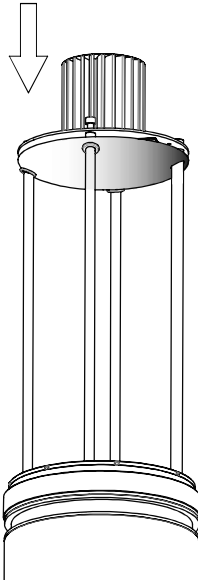
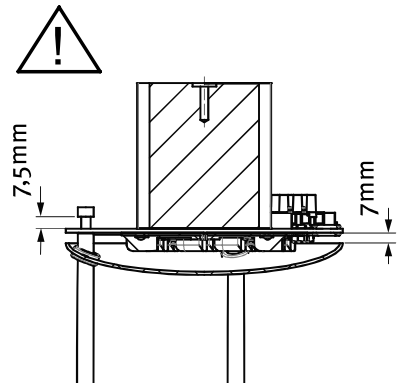
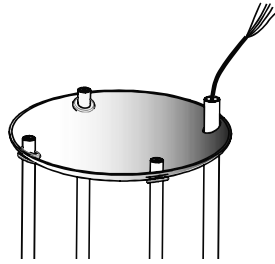
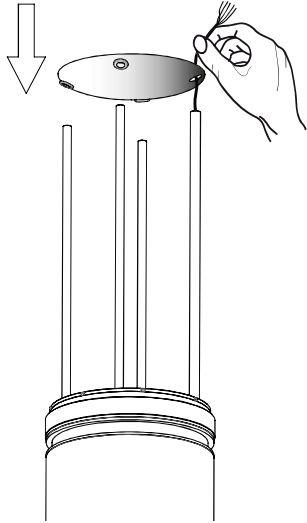

Wichtige Hinweise  
Important Information  
Consignes importantes

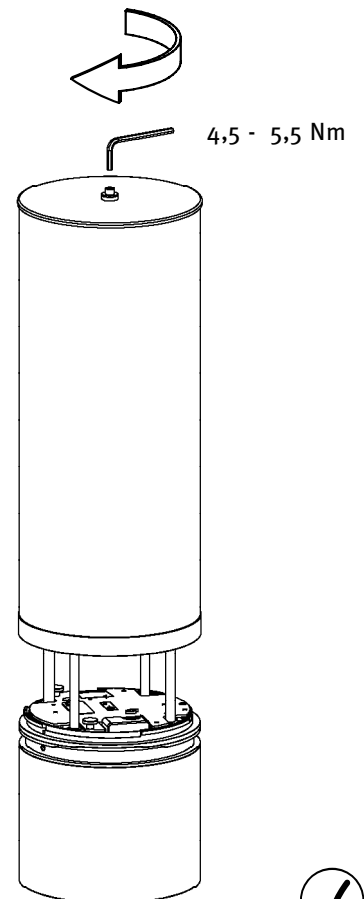

Hess GmbH  
Licht + Form  
Lantwattenstraße 22  
D-78050 Villingen-Schwenningen  
Tel. +49 7721 / 920-0  
Fax +49 7721 / 920-250  
info@hess.eu  
www.hess.eu